

Technical Data Sheet

Product Code: HRA50

Product Name: 50mm Round Handrail

Detailed View

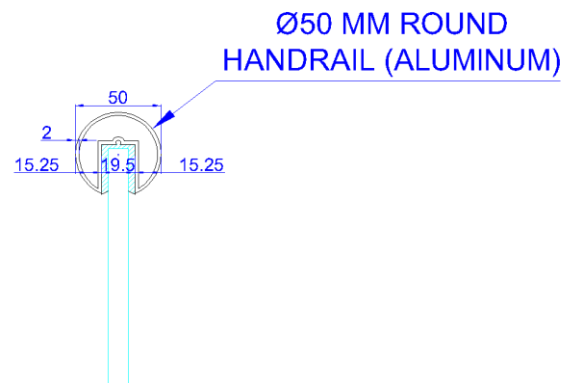
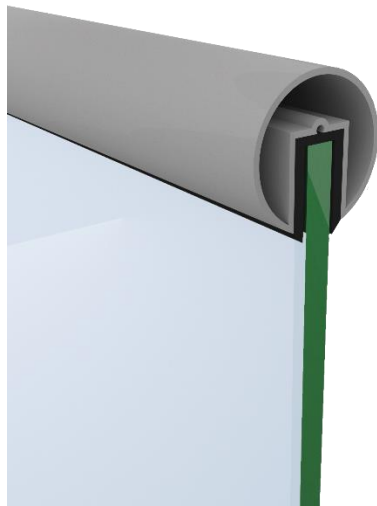

Specification

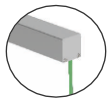

Handrail:

- Material: Aluminium 6063 T6
- Length: 12 / 16 Feet
- Size: 50mm Round
- Thickness: 2.00mm
- Approx Weight: 4.740kg/16 Feet
- Glass Thickness: 12 - 17.52mm



Gasket:

- EPDM Rubber



Powder Coating:

- Type: AkzoNobel
- Color/Shade: As per client preference and subject to availability and feasibility
- Coat thickness: 80-100 Microns
- Coating warranty: 10 years of warranty